



TELEDYNE INSTRUMENTS
Advanced Pollution Instrumentation
A Teledyne Technologies Company

MODEL **300E**

Gas Filter Correlation CO Analyzer



EPA APPROVAL RFCA-1093-093
MCERTS certified Sira MC050069/00
EN Approval EN14626

The Model 300E measures low ranges of carbon monoxide by comparing infrared energy absorbed by a sample to that absorbed by a reference gas according to the Beer-Lambert law. This is accomplished with a Gas Filter wheel which alternately allows a high energy light source to pass through a CO filled chamber and a chamber with no CO present. The light path then travels through the sample cell, which has a folded path of 14 meters.

The energy loss through the sample cell is compared with the span reference signal provided by the gas filter to produce a signal proportional to concentration, with little effect from interfering gases within the sample. This design produces excellent zero and span stability and a high signal to noise ratio allowing extreme sensitivity.

Multi-tasking software gives real time indication of numerous operating parameters and provides automatic alarms if diagnostic limits are exceeded. Built-in data acquisition and internal memory allows logging multiple parameters including average and instantaneous values, calibration data and operating parameters. Stored data are easily retrieved through the serial port or optional Ethernet port via our APIcom software or from the front panel, allowing operators to perform predictive diagnostics and enhanced data analysis by tracking parameter trends.

The Model 300E features rugged construction and is designed to perform with a minimum of attention. In the event maintenance is required, modular construction makes service a simple operation.

- ▶▶ **Standard two year warranty**
- ▶▶ **Ranges, 0-1 ppm to 0-1000 ppm, user selectable**
- ▶▶ **Gas Filter Wheel for CO specific measurement**
- ▶▶ **14 meter path length for sensitivity**
- ▶▶ **Microprocessor controlled for versatility**
- ▶▶ **Multi-tasking software allows viewing of test variables during operation**
- ▶▶ **Continuous self checking with alarms**
- ▶▶ **Bi-directional RS-232 for remote operation**
- ▶▶ **Digital status outputs indicate instrument operating condition**
- ▶▶ **Adaptive signal filtering optimizes response time**
- ▶▶ **GFC wheel guaranteed against leaks for 5 years**
- ▶▶ **Temperature & Pressure compensation**
- ▶▶ **Internal data logging with 1 min to 365 day multiple averages**
- ▶▶ **APIcom remote operation software**

FREE Customer Support by telephone and email for the life of the instrument



MODEL 300E Gas Filter Correlation CO Analyzer

Specifications

Ranges:	0-1 ppm to 0-1,000 ppm full scale, user selectable. Dual ranges and auto ranging supported	Dimensions (HxWxD):	7" (178 mm) x 17" (432 mm) x 23.5" (597 mm)
Units:	ppb, ppm, $\mu\text{g}/\text{m}^3$, mg/m^3	Weight:	40 lbs
Zero Noise:	< 0.02 ppm	Power:	100V - 120V, 220V - 240V, 50/60 Hz, 250W
Span Noise:	< 0.5% of reading above 5 ppm (RMS)	Analog Outputs:	10V, 5V, 1V, 0.1V, selectable
Lower Detectable Limit (LDL):	0.04 ppm	Recorder Offset:	$\pm 10\%$
Zero Drift:	< 0.1 ppm/24 hours, 0.2 ppm/7 days	Serial Outputs:	Serial Port 1: RS-232 (DB-9M) Serial Port 2: standard RS-232 or optional RS-485 (DB-9F), Ethernet
Span Drift:	< 0.5% of reading/24 hours, 1% of reading/7 days	Status (Digital):	8 outputs, 6 inputs (opto-isolated), 4 alarm outputs (optional)
Lag Time:	10 seconds	Current Output:	Optional 4-20mA, select up to three channels
Rise and Fall Time:	< 60 seconds to 95%	Approvals:	USEPA RFCA-1093-093, MCERTS certified Sira MC050069/00 EN14626 Approved, CE and others
Linearity:	1% of full scale		
Precision:	0.5% of reading		
Sample Flow Rate:	800 $\text{cm}^3/\text{min} \pm 10\%$		
Operating Temperature Range:	5 - 40°C (with EPA Equivalency)		

NOTE: The values expressed above are in accordance with EPA definitions. All error specifications are based on constant conditions. Specifications exceed US EPA and Eignungsgeprüft requirements.

Schematic

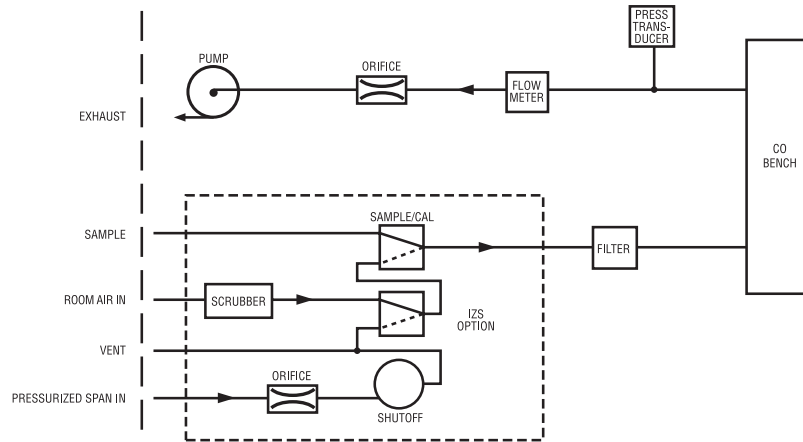

How to Order

Model 300E Gas Filter Correlation CO Analyzer includes:

- Standard two year warranty
- Internal pump
- Auto ranging and dual ranges
- 47mm diameter particulate filter
- 8 isolated digital status outputs
- 6 isolated digital inputs
- Bi-directional RS-232
- APIcom remote control software

Specify input AC voltage & frequency:

- 100V - 115V 50Hz
- 220V - 240V 60Hz

Specify output DC voltage:

- 10V 5V 1V 0.1V

Calibration Options:

- TFE valves for selection of customer-supplied zero and span gas
- Internal zero air scrubber

Additional Options:

- Rack mount brackets (19") with chassis slides
- Rack mount brackets only
- 4-20mA outputs (specify up to three channels)
- Multi-drop RS-232 connection

- RS-485 communications
- Ethernet

Calibration Valves:

- Stainless steel valves for selection of customer-supplied zero and span gas
- Shut-off valve and flow control for external span gas cylinder
- Internal zero air scrubber

Accessories:

- RS-232 Cable
- Expendables Kit
- Spare Parts Kit

Specifications subject to change without notice. Printed documents are uncontrolled. SAL000011 A (DCN 5058) M300E/08/08/08.



TELEDYNE INSTRUMENTS
Advanced Pollution Instrumentation
A Teledyne Technologies Company

9480 Carroll Park Drive ■ San Diego, CA 92121-5201
Ph. 858-657-9800 Fax 858-657-9816
Email api-sales@teledyne.com

For more information about the Teledyne API family of monitoring instrumentation products, call us or visit our website at

www.teledyne-api.com

