

8872

Users Manual Cable, Pipe and Camera Locator

RYCOM Instruments
9351 East 59th Street
Raytown, MO 64133

816.353.2100
800.851.7347
Fax: 816.353.5050

www.rycominstruments.com
rycom@rycominstruments.com

now that the world is wired...



where in the world is your wire?

Part Number:
030-00066-00

Table of Contents

GENERAL INFORMATION

Introduction	2
Prepare for Use	2

TRANSMITTER OPERATION

Direct Connection	4
Coupler Connection	4
Inductive Connection	5
Blind Search	5
Notes on Selecting the Tracing Signal	6

RECEIVER OPERATION

Locating the Cable or Pipe	7-8
Selecting the Locating Mode	9
Peak Mode Locating	9-10
Null Mode Locating	10
Absolute Signal Strength	11
Signal Strength Adjusted for Depth (current measurement)	11
Gain Change Indication	12
Passive 50/60 Hz Locating	12
Push Button Digital Depth	13
Depth Measurement 45° Angle Method	13
Tilted Magnetic Field Identification	14

FAULT LOCATING WITH THE 8872

Introduction	15
Ground Return Probe	15-17

SONDE LOCATING WITH THE 8872

Introduction	18
Locating the Sonde	18-20
Specifications	21-22
Factory Service	23
Warranty	23

Introduction Congratulations on the purchase of your new RYCOM Cable, Pipe and Fault Locator. The 8872 Series is specially designed to detect buried power cables, CATV cables, gas and water pipes, sewer lines, telephone cables, fiber optic cables with sheath, inspection camreas and sondes.



Warning

The 8872 is designed to detect the electromagnetic field emitted from buried metallic utilities. There are buried cables, pipes, and utilities this instrument cannot detect. LOCATING is not an exact science. The only way to be sure of the existence, location or depth of buried utilities is to expose the utility.

DISCLAIMER OF LIABILITY

RYCOM SHALL NOT BE LIABLE TO DISTRIBUTOR, RESELLER, OR ANY OTHER PERSON FOR ANY INCIDENTAL, INDIRECT, SPECIAL, EXEMPLARY OR CONSEQUENTIAL DAMAGES, OR INJURY OF ANY TYPE WHATSOEVER, AND CAUSED DIRECTLY OR INDIRECTLY BY PRODUCTS SOLD OR SUPPLIED BY RYCOM INSTRUMENTS, INC..

The TRANSMITTER applies a tracing signal onto a cable or pipe. The RECEIVER detects the tracing signal. You can locate the relative position of the buried pipe or cable by following the tracing signal.

Part Numbers

8872 Cable, Pipe and Fault Locator

RECEIVER	001-00160-00
TRANSMITTER (D-CELL)	001-00161-01
USER'S MANUAL	030-00066-00
TRAINING VIDEO	035-00001-00
RED/BLACK CORD(SMALL CLAMPS)	151-00051-00
OR	
RED/BLACK CORD(LARGE CLAMP)	151-00052-00
GROUND ROD	211-00006-01
6 - DURACELL "C" BATTERIES	770-00022-00
8 - DURACELL "D" BATTERIES	770-00023-00
(NON-RECHARGEABLE TRANSMITTER ONLY)	

8872 Accessories

HARD INDUCTIVE CLAMP	100-00134-00
GROUND RETURN PROBE	001-00087-01
512Hz SEWER SONDE	001-00116-02
HEADSET	743-00013-00

Prepare for Use

Unpack your new RYCOM locator. Make sure there is no shipping damage and all the parts are included.

Locate the battery compartment on the back of the "head" of the RECEIVER. Open the compartment using a phillips screwdriver. Install the six Duracell "C" batteries as marked.

Locate the battery compartment inside the TRANSMITTER. Remove the black battery compartment door. Install the eight Duracell "D" batteries as marked.

Note: For longer battery life and reliable operation under adverse conditions, use only Duracell alkaline batteries.

8872 Series Transmitter Controls and Indicators

figure - 1

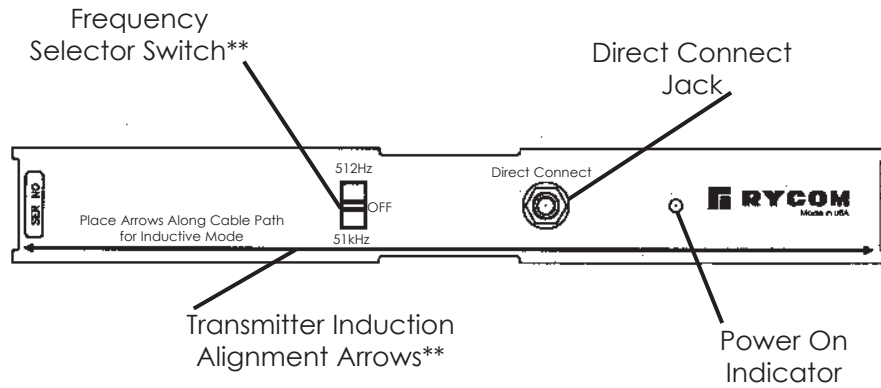

TX OUTPUT (SIGNAL OUTPUT JACK)

The TX OUTPUT is the jack. The RED/BLACK CORD, Coupler and FLEXICOUPLER connects to create a circuit on the buried utility.

TX ON

When lit, the red LED light indicates the TRANSMITTER is on.

OUTPUT FREQUENCY CONTROL

The 51kHz (RF) reading indicates that the 51kHz frequency is in use. This frequency is the higher of the two. The 51kHz frequency is often used to locate sharp corners in cables or pipes and is capable of jumping disconnected shield bonds or grounds. The 512Hz (AF) reading indicates that the 512 Hz frequency is in use. The 512Hz is the lower frequency. It is less susceptible to locating errors caused by adjacent cables or pipes. Also, by using the 512Hz frequency, the locating range is greater.

Direct Connection



CAUTION DO NOT CONNECT TO LIVE OR ENERGIZED POWER CABLES

Direct Connection is the most reliable method of signal application. This method is relatively free of interference. The greatest amount of signal strength can be achieved by this method. Both low and high frequency may be used. The far end of the utility must be grounded.

Connect the RED TEST CORD to an existing ground point or an exposed metallic section of the utility. Place the GROUND ROD approximately 10 feet from this point, at an angle of 90° to the buried cable or pipe. Push the GROUND ROD into the ground 8 to 10 inches. Connect the BLACK TEST CORD to the GROUND ROD.

Plug the RED/BLACK TEST CORD into the TX OUTPUT JACK. Set the FREQUENCY switch to the 512Hz or 51kHz. The TX ON indicator will light up.

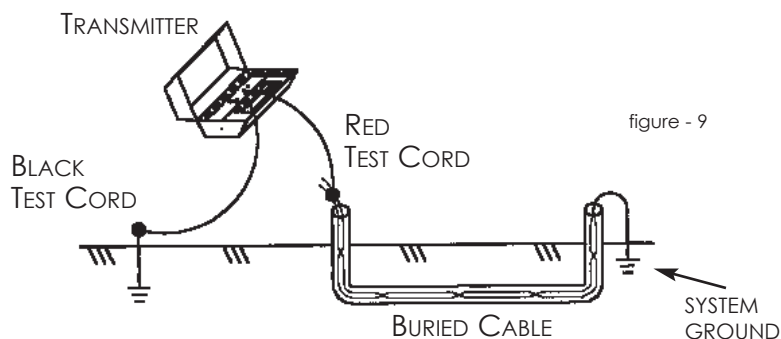

Flexicoupler Connection

The optional FLEXICOUPLER and HARD COUPLER are very easy to use, and services do not have to be interrupted. The operation range is shorter than for Direct Connection methods. The tracing signal can be affected by neighboring cables and pipes. The RED/BLACK TEST CORD or the GROUND ROD are not needed for this method.

Successful COUPLER operation requires an insulated conductor that is grounded on both near and far ends.

Loop the FLEXICOUPLER around the cable and connect the two ends, or clamp the HARD COUPLER around the cable. It is important to connect the COUPLER around the cable needing to be traced. Connect the COUPLER around the wire closer to the outgoing cable not near the system ground. The result will be a stronger signal. By connecting near the grounding, the range will also be shorter, and difficulty may arise determining one cable from another.

Plug the COUPLER TEST CORD into the TX OUTPUT JACK. Always use the 51kHz FREQUENCY on the RECEIVER and the TRANSMITTER.

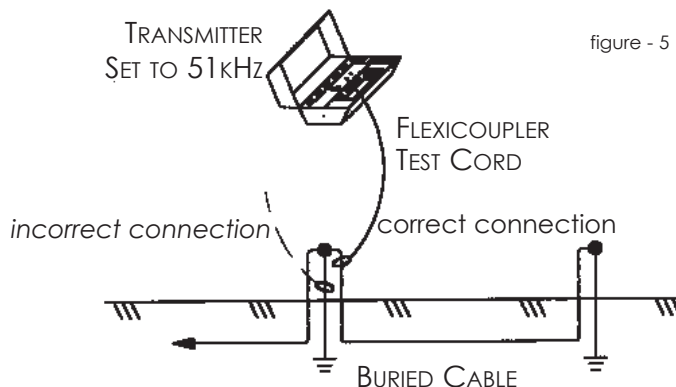

Inductive Connection

This method is convenient to use, and services are not interrupted. No test cords or connections are needed. The cable or pipe must have good insulation or non-conductive coating, or the operating range will be short.

Place the TRANSMITTER on the ground, as close as possible to the path of the cable or pipe. Align the ARROWS on the TRANSMITTER CONTROL PANEL at a moderate angle to the cable or pipe. Set the FREQUENCY switch to the 51kHz position. Turn the TRANSMITTER ON. First, locate the broad TRANSMITTER Null, then move toward the expected cable path while looking for the signal carried by the cable.

Start tracing the path with the RECEIVER 25 feet from the TRANSMITTER. Search in the 90° zone as shown above. Locate the cable or pipe, and follow the path. If the signal becomes weak, move the TRANSMITTER to a point 25 feet behind the last strong signal, and continue searching.

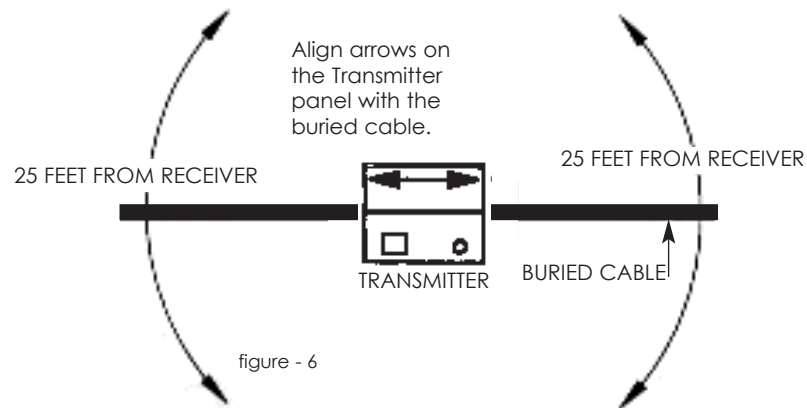

Blind Search

The Blind Search locating techniques is used if the operator is not aware if a buried utility exists. Two people are needed for this technique. The TRANSMITTER and the RECEIVER are placed 25 feet away from each other. Each operator walks at the same speed keeping a distance of 25 feet from each other. When the receiver gives an audio response, then a buried utility is present between the RECEIVER and the TRANSMITTER.

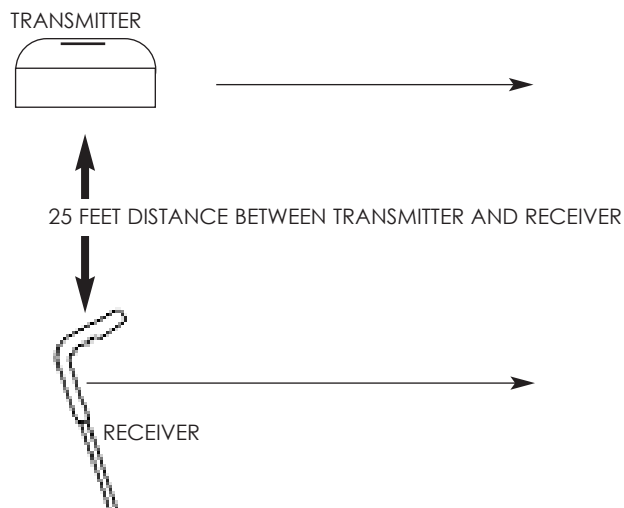

Notes on Selecting the Tracing Signal

The choice of 512 Hz or 51 kHz Frequency is dependent on the conditions of the locate.

The 512 Hz and 51 kHz signals each have their advantages. Use 51kHz and 512 Hz in combination for the highest confidence in locating the path. Begin by using the 512 Hz signal, and continue as long as you are confident in the results. If the signal suddenly becomes very weak, disappears, or takes an unexpected turn, change to the 51 kHz signal to verify the results.

The 512Hz (lower frequency) signal is usually preferred to the 51 kHz (higher frequency) signal, because it is much less susceptible to locating errors caused by nearby cables or pipes. The 512 Hz locating range is also much longer than the 51 kHz signal. The 512 Hz signal will not travel well through disconnected shield bonds or insulated pipe bushing. The problems need to be inspected and corrected as the locating continues.

The 51 kHz (higher frequency) is sometimes better than the 512 Hz (lower frequency) for locating sharp corners in cables or pipes. The 51 kHz signal is also better for "jumping" disconnected shield bonds or grounds, or tracing signal may indicate one of these characteristics. The locating range is quite short for the 51 kHz signal, however, so the TRANSMITTER must be repositioned more often during the tracing operation. This FREQUENCY is also useful for applying a signal using the FLEXICOUPLER.

8872 Receiver Controls and Indicators

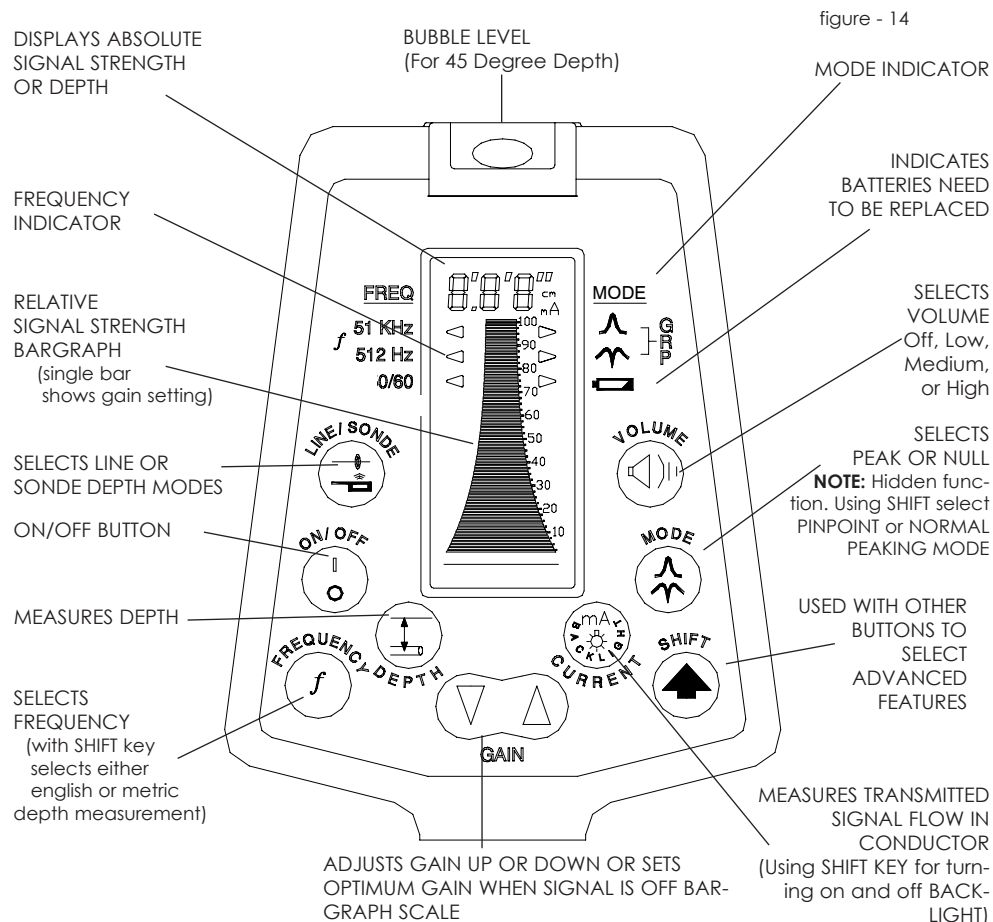

ON OFF Button

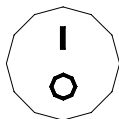

Press the ON OFF button to turn the RECEIVER on (if currently off) or off (if currently on). Upon turning the unit on, it will load the settings from the previous usage. Upon turning the unit off, the settings will be saved within the unit to be recalled next time the unit is used.

Note: Unit will automatically shut off if no keys are pressed within a 10 minute period.

FREQUENCY Button

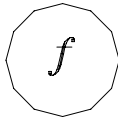

Press the FREQUENCY button to switch the RECEIVER frequency from 51 kHz, 512 Hz, and 50/60 Hz. With each press of the key, it will toggle through the different frequencies in order.

DEPTH Button

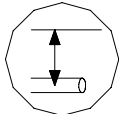

Pressing the DEPTH button will cause the RECEIVER to first display the mode of the depth (Line or Sonde) and then the depth will be measured. To change the Depth Measurement from English to Metric, hold SHIFT and press FREQUENCY. To change LINE and SONDE use the LINE/SONDE key.

GAIN Button (Up or Down)



Used to adjust the gain level for the receiver. When the GAIN button is pressed, the RECEIVER will adjust the gain up or down. If the signal strength shows as " --- " on the display and a GAIN up or down key is pressed, the unit will automatically adjust to 90 on the scale display.

8872 Receiver Controls and Indicators Continued

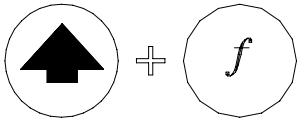

SHIFT with the FREQUENCY (ENGLISH/METRIC) Button

Press the SHIFT and the FREQUENCY buttons to toggle the units for display of the device. When pressed it will toggle between English and Metric units. When in Metric the display will show - **cm** - in the top of the display. When in English, the display will show - ' " - in the top of the display.

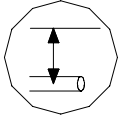

LINE/SONDE

Press to toggle the depth mode from Line to Sonde modes. When in Line mode the display will show LIN in the top of the display. When in Sonde mode the display will show SON in the top display.



CURRENT Button

Press the CURRENT button to measure the amount of current that is flowing while in the 512 Hz or 51 kHz frequency modes.

Note: The CURRENT button will not work when in the 50/60 Hz frequency modes.



MODE Button

Press the MODE button to toggle between PEAK and NULL locating modes. Hold SHIFT and press MODE to select PINPOINT Peak Mode or NORMAL Peak Mode. PIN will appear in the display to indicate PINPOINT and NOR will appear in the display to indicate NORMAL.

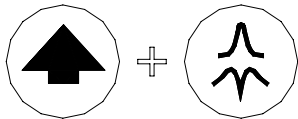

REFIND PEAKING MODE

The 8872 has a hidden function. To activate PIN Peaking Mode hold The SHIFT key and press the MODE key. "Pin" will appear at the top of the display. Repeat the process to switch back to NORMAL Peaking Mode "nor" will appear at the top of the display. The unit resets to NORMAL when turned off.

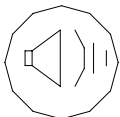

VOLUME Button

Press VOLUME button to toggle the volume of the device from High, Medium, Low and Off. When this key combo is pressed, the volume level will be toggled through the four volume levels in order.

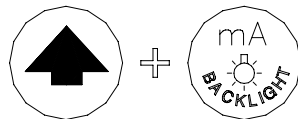

BACKLIGHT

Hold the SHIFT Key and press the CURRENT key to toggle on and off the back light.

8872 Head Phone Jack

The 8872 can be used with headphones. The jack is located on the back of the receiver head and is labeled with earphone insignia.

Locating the Cable or Pipe

Make sure the TRANSMITTER is connected and in the ON position. Then move approximately 15 feet away from the TRANSMITTER along the path. (Move about 25 feet for the Inductive search mode.)

Hold the RECEIVER so that you can see the LCD bargraph and controls easily. Make sure the RECEIVER and the TRANSMITTER FREQUENCY are both set for the same FREQUENCY, either 512 Hz (lower) or 51 kHz (higher). Or select one of the two passive locating modes which do not require the transmitter

Selecting the Locating Mode (Peak or Null)

Press the MODE button to select the desired Peak or Null locating method.

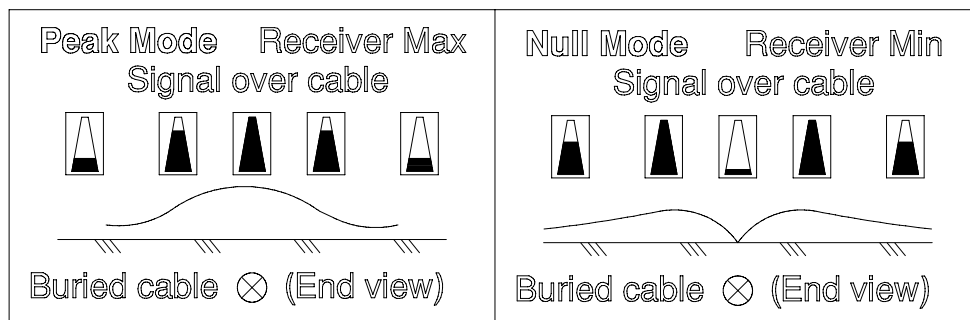

Peak Mode Locating

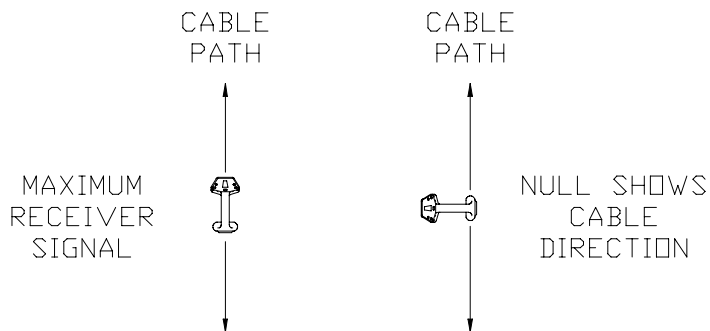

Keep the RECEIVER in a vertical position. Move the RECEIVER left to right across the path. When the RECEIVER is directly above the cable or pipe, rotate the RECEIVER for a maximum signal. As you move the RECEIVER away from the cable path, the meter reading (and audio frequency response) will drop off.

If you rotate the RECEIVER while over the cable, a sharp NULL will identify the cable's direction. It is aligned with the flat side of the RECEIVER.

Peak Mode Locating Continued

Trace the path by walking away from the TRANSMITTER at a moderate pace. Move the RECEIVER to the left and right while walking, following the PEAK indications.

As you trace the path, the PEAK meter reading may slowly fade as you move away from the TRANSMITTER. Press and release the GAIN buttons as needed to compensate for changes in level (higher or lower). One of the following may OCCUR:

- a) a junction where the signal divides and goes several directions.**
- b) a break in the cable or shield.**
- c) a change in the depth of the cable or pipe.**
- d) an insulated pipe fitting.**
- e) a slack loop of cable.**

If you can no longer trace the path, even with the GAIN set to maximum, connect the TRANSMITTER to the far end of the path and trace back to the point where you lost the signal.

Mark the straight sections of the path every few feet. Mark sharp curves, loops, and cable bundles every few inches. Sharp changes in the path cause the RECEIVER PEAK and NULL indications to behave differently than when tracing a straight path. Practice on the path that you know has turns and laterals in it. This will help you to recognize the conditions within the field.

Null Mode Locating

Move the RECEIVER left to right across the cable path. When the RECEIVER is directly above the cable or pipe, a NULL (lowest meter reading and lowest audio tone) will occur. When moving the RECEIVER to left or right of the NULL point, the meter reading will rise to a maximum point (PEAK). The audio tone will also be at its highest pitch. When the RECEIVER is moved beyond the PEAK, the meter reading will begin to fade.

Trace the path by walking away from the TRANSMITTER at a moderate pace. Move the RECEIVER to the left and right when walking, following the NULL indications.

As you trace the path, the PEAK meter reading may slowly fade as you move away from the TRANSMITTER. Press and release the GAIN buttons as needed to compensate for changes in signal level. If the PEAK meter readings suddenly changes in level (higher or lower), one of the following may have occurred:

- a) a junction where the signal divides and goes several directions.**
- b) a break in the cable or shield.**
- c) a change in the depth of the cable or pipe.**
- d) an insulated pipe fitting.**
- e) a slack loop of cable.**

If you can no longer trace the path, even with the GAIN control set to maximum, connect the TRANSMITTER to the far end of the path, and begin tracing the path back.

Mark the straight section of the path every few feet. Mark sharp curves, loops, and cable bundles every few inches. Sharp changes in the path causes the RECEIVER PEAK and NULL indicators to behave differently than when tracing a straight path. Practice on the path that you know has turns and laterals in it. This will help in recognizing the conditions within the field.

Absolute Signal Strength

The 8872 RECEIVER provides the operator with a direct measurement of the RECEIVER's signal strength. The measurement is displayed with three numerical digits (ex: **485**) located at the top of the LCD display. The measurement range is from 0 to 999 indicating a very weak signal (0) to a very strong signal (999). Absolute Signal Strength is independent of the GAIN setting or meter reading. It gives the operator information about the actual amount of signal being radiated from the conductor and received by the RECEIVER.

Measuring Absolute Signal Strength at any time is done by reading the number at the top of the LCD display. The Absolute Signal Strength will not be displayed if the meter reading is too high or too low. Adjust the GAIN to move the meter reading to mid-scale. The numerical display will change from '---' to a valid measurement.

Absolute Signal Strength measurements are more sensitive to signal changes than the meter display. PEAKS and NULLS can be more precisely pin-pointed. This measurement can also be used to monitor signal loss as the conductor is being traced.

Current Measurement

The 8872 RECEIVER contains a feature that is very useful in identifying a desired cable in a field of various conductors and/or utilities. It is not unusual for the target conductor (the conductor connected to the transmitter) to induce a signal into nearby conductors in a crowded field. In these instances, the radiated signal on the conductors close to the surface of the earth, may be stronger than the TRANSMITTER signal on the target conductor buried deep in the ground. The operator will find two or more paths and must determine which is the target conductor. By using the current measurement feature of the 8872 RECEIVER, the operator can determine the amount of 512 Hz or 51 kHz current flowing on the conductors, regardless of the depth. The highest current flow indicates the target conductor.

Begin this measurement by locating the path of the cables to be compared. Mark these locations as accurately as possible (see the sections on Peak Mode Locating and Null Mode Locating). Place the RECEIVER vertically over one of the conductor marks and rest the foot of the locator on the ground. Holding the RECEIVER vertical, press and release the CURRENT button. When the meter changes from a "thermometer" type display to a "bar" type display, hold the RECEIVER still until the measurement stabilizes. The blinking bar indicates the signal level on the cable (adjusted for depth). Next, move to the second cable and repeat the measurement. The blinking bar will show the signal level on the conductor. In addition, the previous reading is shown as a solid bar. The higher of these two readings will show which conductor is carrying the greatest locating signal.

Note:

The 8872 is designed to alert the operator of potential current measurement errors. If the display reads **'Err'** during a current measurement, the RECEIVER has detected a condition that could produce inaccurate readings.

Errors can exist when the conductor signal flow is too small. Check TRANSMITTER hookup and far end access point for poor connections. This cause of error can be identified by a high GAIN setting (80 or greater on the bargraph display).

The RECEIVER may also be detecting adjacent cables or is not directly over the target conductor. Verifying target conductor path precisely before measuring current again.

If at anytime the display reads **'CAL'**, contact RYCOM.

Gain Change Indication

The GAIN up and down buttons are used to increase and decrease the gain in small amounts. If the meter reading is very low, pressing the GAIN up button will center the meter reading to mid-scale. Likewise, if the meter reading is very high, pressing the GAIN down button will center the meter reading to mid-scale.

Passive 50/60 Hz Locating

The 8872 RECEIVER is capable of locating power utility frequencies. This MODE is useful for locating underground primary and secondary power utilities. In certain circumstances, this MODE will also locate water pipes, sewer lines, cable television, and telephone. The reason is that common electrical grounds are sometimes found among these various utilities.

Select the 50/60~ (Hz) frequency on the RECEIVER. Select PEAK mode. Locate the conductor using the PEAK mode.

This method is useful because of its speed and convenience. Start at a known reference point and keep in mind that other conductors in the area may produce this same locating signal.

The TRANSMITTER is not required to locate in this mode.

Push Button Depth

**The only way to be sure of the depth of a utility is to expose the utility.
At any given time, the depth readout may be inaccurate.**

The 8872 RECEIVER can measure depth with the push of a button. The depth is displayed at the top of the LCD display in feet or inches (meters and centimeters if requested). Push button depth is useful in quickly determining the depth of the conductor during path locating.

Begin this measurement by locating the path of the cable or pipe. Move to the location where you want to measure the depth. Stay at least 15 feet away from the TRANSMITTER. Pin-point this location as accurately as possible (see Peak Mode Locating page 19, Null Mode Locating page 20 and Absolute Signal Strength page 21). Place the RECEIVER vertically over the conductor and rest the foot of the locator on the ground. While holding the RECEIVER vertical, press and release the DEPTH button. The RECEIVER will briefly indicate a measurement is being performed and then display the depth at the top of the LCD display.

Caution must be exercised when using the push button depth feature, as tilted magnetic fields and adjacent conductors can significantly influence this measurement. The operator should periodically check for adjacent conductors and tilted magnetic fields when taking push button depth readings. For information on identifying tilted magnetic fields, refer to Tilted Magnetic Field Identification and Depth Measurement 45° Method.

Depth Measurement 45° Angle Method

Move to the location you want to measure depth. Stay at least 15 feet away from the TRANSMITTER. Move the RECEIVER left to right across the path until the cable is located. Mark the path on the ground as precisely as possible using the Null Method.

Place the RECEIVER on the ground with the LCD meter facing up. Position the unit so that the BUBBLE LEVEL on top of the meter is centered (45°). Pull the RECEIVER away from the cable path (at 90° to the cable path) keeping the BUBBLE LEVEL centered. When the locator indicates a NULL reading, mark the location of the locator's foot. The distance between the RECEIVER and the cable path is the depth of the pipe or cable.

A false depth reading may be caused by nearby buried metallic objects, such as a second cable, pipe, sewer, fence or railroad track. Confirm the depth measurement by repeating the above steps on the opposite side of the pipe or cable.

A variance greater than 5 inches in depth measurement may indicate the presence of additional buried cables, pipes or other objects.

figure - 17

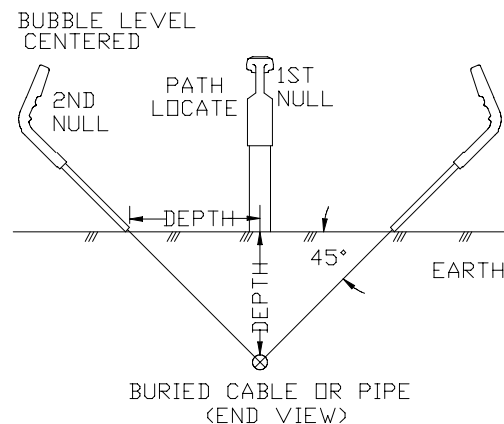

Tilted Magnetic Field Identification

When adjacent cables or pipes are present, they will sometimes create locating errors. Some of the TRANSMITTER signal is picked up by the adjacent conductors and is redirected so that it combines with the original signal. The result is a Tilted Magnetic Field. This is often the reason that numeric depth readouts are sometimes created in error.

The operator can verify the accuracy of path locate by performing the 45° Angle Method locate on both sides of the cable path. If the right and left side depth readings agree to within 5 inches, the path locate is accurate. If the two depth readings do not agree, then **dig with care**. A closer locate would be halfway between the two outside depth locate marks.

This is an important technique that should be used to ensure the most accurate location possible.

Fault Locating with the 8872

Fault locating determines the position of an insulated break on an underground conductor. In the case of an insulation fault, some of the signal will return to the TRANSMITTER attached to the GROUND ROD through a break in the insulation.

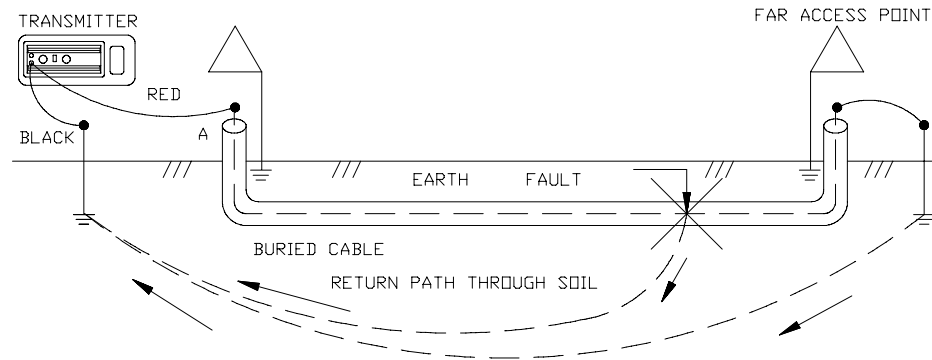

Signal Return Through an Insulated Fault

It is generally a good idea to locate the conductor path before attempting to fault locate. If, during the path locate, an unusual amount of signal loss occurs, a part of the signal has escaped to ground in the last several feet.

Note: Signal would go to ground at a grounded splice point, which would act as a fault during the path and fault locate.

Once the path is determined and there is a general area where a fault is expected, additional current can be forced to flow through the fault by disconnecting and isolating the far access point. If the current has no path to ground at the far access point, it will be forced to seek ground at the fault. This will increase the current in the soil at the fault and detection of the fault.

Ground Return Probe

To begin fault locating, open the GROUND RETURN PROBE (GRP) and attach the 8872 RECEIVER as shown below. Plug the GROUND RETURN PROBE CORD into the GRP handle with the straight connection. The GROUND RETURN PROBE is collapsible for easy transport and storage.

Collapsible Ground Return Probe

figure - 19

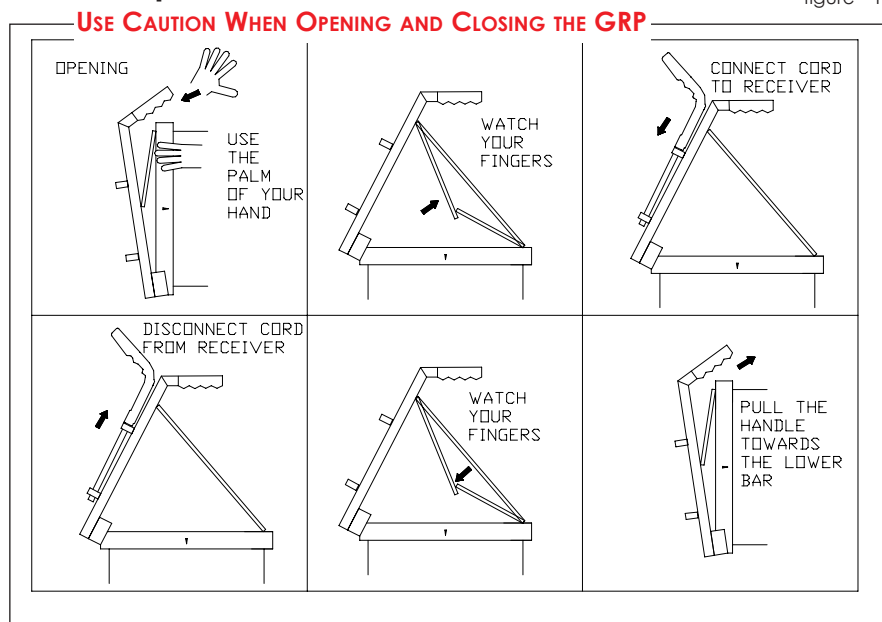

Ground Return Probe Insertion

Circuitry between the ground spikes provides a path for current in the soil returning to the GROUND ROD. The current enters one spike of the GROUND RETURN PROBE and exits the other spike. The GRP should be inserted into the soil with consistent force and depth.

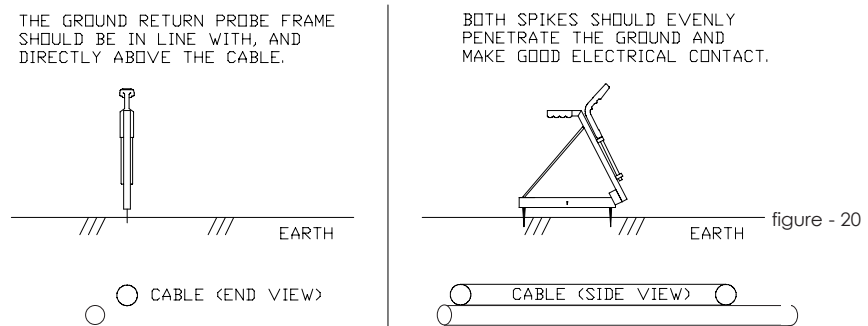

The current in the soil spreads out from the fault like the spokes of a wheel. The current is highly concentrated in the soil near the fault as it begins its return, and near the GROUND ROD as it finishes its return. Notice that the current is widely dispersed in the soil between the fault and the GROUND ROD.

figure - 21

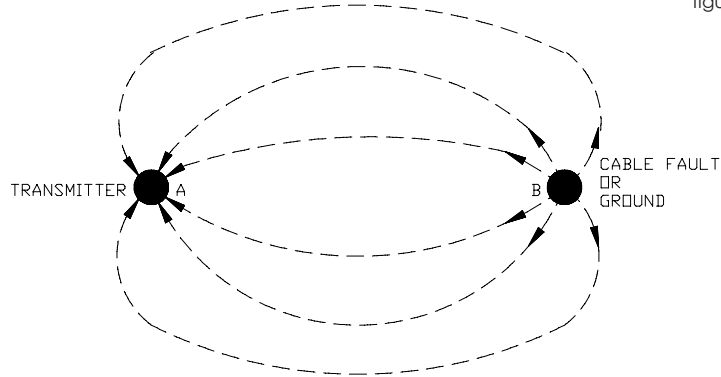

Ground Return Probe Fault Locating

As you walk the path using the GRP, drop the probe every three or four steps. As you near an area of high current concentration in the soil, the GROUND ROD or the fault, the RECEIVER will record higher and higher readings. You will find it necessary to reduce the RECEIVER's sensitivity by pressing the GAIN CONTROL button. Once the signal starts to increase, you should slow down and take smaller steps, covering smaller segments of ground to avoid passing the fault.

The RECEIVER will continue to record higher current readings until one spike of the GROUND RETURN PROBE passes the fault. When one spike of the GRP is on each side of the fault, the currents will subtract and produce a NULL. To record the deepest NULL, press the GAIN CONTROL button to keep the NULL on the meter scale and move the GRP an inch at a time until the deepest NULL is recorded. The fault lies in the center of the GROUND RETURN PROBE spikes.

figure - 21

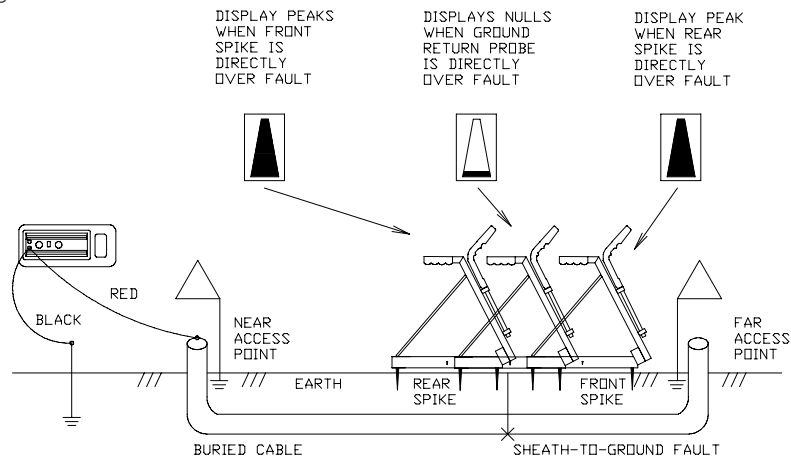

GRP Receiver Meter Response with Distance

Notice in the figure below (figure 22), there is a RECEIVER signal level increase as the GROUND RETURN PROBE approaches a fault and it moves away from the TRANSMITTER. A good cable will allow the locating signal to slowly decrease with distance from the TRANSMITTER. While this signature pattern must be recognized, this method is usually more accurate than phase responding to-from types of instruments.

figure - 22

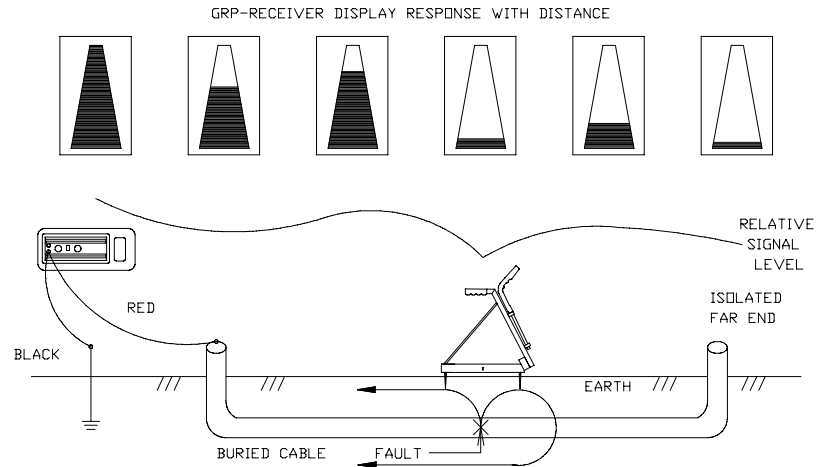

Faults Beneath Paved Surfaces

A potential problem could exist if a fault should lie beneath a paved surface. In this case, the GROUND RETURN PROBE will be used in the dirt at the side of the paved area. Since the return current in the soil begins its return from the fault - like the spokes of a wheel laying on the ground - equal amounts of current will enter the GRP if it is placed on the ground and positioned broadside to the fault. A NULL will be recorded when the exact broadside is accomplished. The GRP adjustments can be made by slightly rotating the GROUND RETURN PROBE to find the deepest NULL. The fault will lie on a straight line projected at a right angle from the center of the GRP. The operator should record this line over the paved area. By repeating this procedure from another location near the paved area, another line will be produced. The intersection of the two lines is the location of the fault.

figure - 23

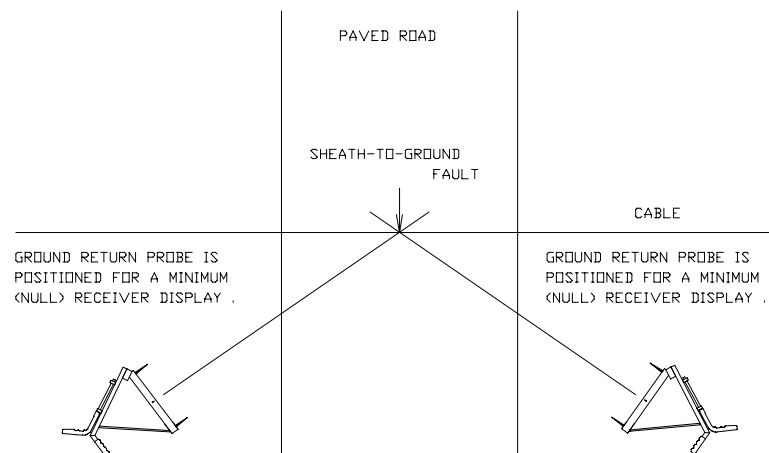

Locating a Sonde Using the 8872 Series

Before you begin, you must choose a SONDE that will match the same frequency as the RECEIVER. You will need a SONDE with a frequency of 512 Hz to use with the 8872 Receiver.

The key to SONDE locating success is practice and patience. Before going out on your first locate, it is a good idea to take your RECEIVER and SONDE out and try locating the SONDE and calculating the depth.

figure - 24

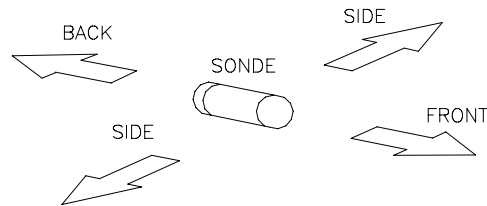

Attaching a Push Device to the Sonde

You will also need to attach a push rod to the SONDE. This can be accomplished by using the coupling on the end of the SONDE. We recommend using a spring coupling to allow the SONDE to move easier. Or, if you are needing to attach the SONDE to a sewer snake or an auger, it is recommended you use duct tape and apply as the shown in the figure below. If taping the SONDE on a metal pushing device, it is recommended to place the battery side of the SONDE closest to the device. This will allow for the best performance. Wrap the snake for approximately 1 foot in the location where the SONDE is going to be attached. Also attaching the SONDE 18 inches behind the cutting head is recommended. First, wrap the SONDE in the duct tape and then attach the SONDE to the snake using the duct tape.

figure - 25

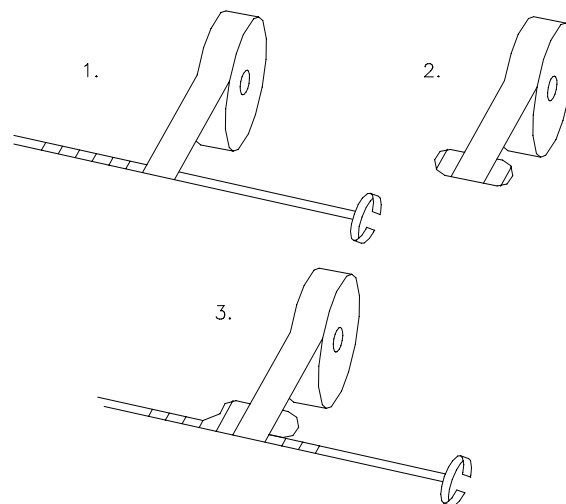

Locating a Sonde

Set the RECEIVER to the SONDE . Next, hold the RECEIVER antenna directly above and in line with the SONDE, as shown below. The RECEIVER sensitivity needs to adjusted for a meter reading indication between 60% to 80%.

The radiation pattern of the SONDE is shown below. The PEAK signal is when the RECEIVER is held directly over the SONDE with the antenna in line with the SONDE. Both behind and in front of the SONDE ghost signals can be located. By locating the ghost signals, the user is confirming the accuracy of the locate.

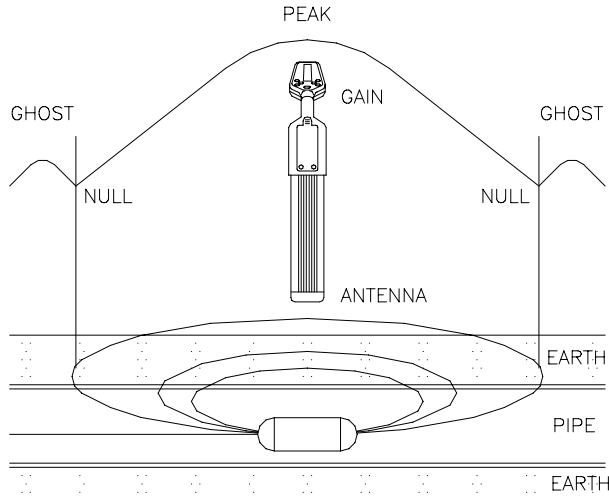

Start by following the suspected path of the pipe and use the 8872 RECEIVER to locate the SONDE. Stop locating when the PEAK reading is found. Then rotate the RECEIVER as shown in the figure below. When pivoting the RECEIVER, do not change the vertical position. The RECEIVER will indicate a PEAK when the RECEIVER antenna is in line with the SONDE.

figure - 27

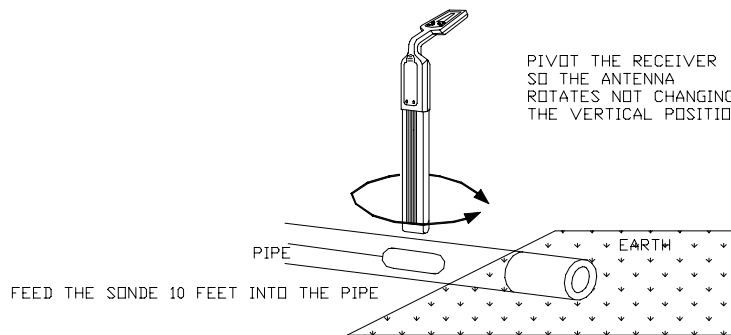

Now move the RECEIVER side to side (across the path of the pipe) as shown below. When the PEAK is found, the RECEIVER is directly over the SONDE. Mark this location. Next, check for ghost signals in front of and in back of the SONDE to confirm the location.

figure - 28

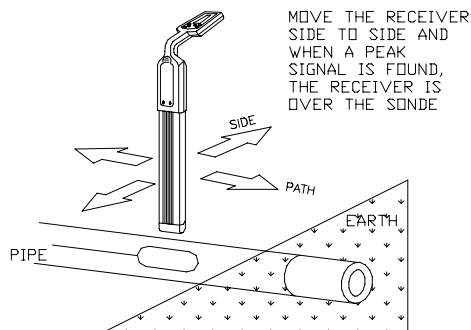

Depth Measurement When Using the Sonde

Once the SONDE has been located, the depth can then be found. Refer to the figure below for a reference. Start by moving the RECEIVER along the path behind the SONDE with the antenna in line with the SONDE and find a NULL between the PEAK ghost signals. Mark this point (A). Then move the RECEIVER along the path in front of the SONDE and find another NULL. Mark this point (B). Next, measure the distance between these two points. The depth of the pipe is 0.7 times the distance between the two points.

figure - 29

DISTANCE OF PIPE = .7 TIMES THE DISTANCE BETWEEN THESE POINTS

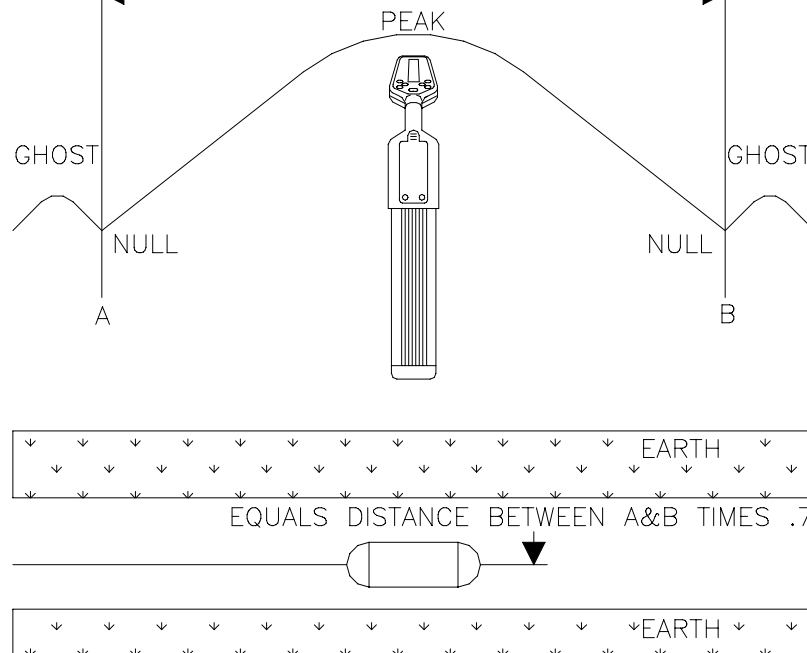

The 8872 is specially designed to measure the SONDE depth digitally. To use this feature, the RECEIVER must be placed in the position shown in the diagram above. The RECEIVER antenna must be in line with the SONDE. The RECEIVER must also be in the SONDE mode (page 21, Shift with the Depth). Locate the SONDE as described previously. When the SONDE has been located, press the DEPTH button. The LCD display will indicate dEP, SON and display the depth of the SONDE in feet or meters.

8872 Specifications

Receiver

Operating Frequency	51 kHz • 512 Hz • 50/60~
Antenna Mode	Null (vertical coil) • Peak (horizontal coil)
Audio Indication	variable pitch audio
Current Measurement	display indicated relative current simultaneously between any two selected cables for target cable verifications in a multi-conductor environment
Operating Temperature	-4°F to 133° (-20°C to +55°C)
Battery Type	6 - "C" Duracell alkaline batteries
Battery Life	
Continuous	40 hours
Intermittent	82 hours (10 minute auto shut off)
Dimensions	30.3" x 3.75" x 9.4"
Weight	3 pounds
Signal Strength	analog LCD bargraph Absolute Signal Strength readout 0 - 999
Gain Control	up/down button for automatic centering and manual control
Dynamic Range	126 dB
Depth Measurement	
Automatic	push button 3 digit readout to 15 feet
Manual	bubble level triangulation for verification of automatic readout in congested environments

8872 Specifications

Transmitter

Operating Frequency	51 kHz • 512 Hz
Operating Temperature	-4°F to 133° (-20°C to +55°C)
Hook-up Method	Direct Connection Inductive Coupling (with optional coupler) Transmitter Induction
Max Open Voltage	30 V PK-PK AC
Output Power	100 Milliwatts, Nominal
Battery Types	8 - "D" Duracell alkaline batteries
Battery Life	greater than 120 hours*
Dimensions	16" x 6.32" x 5"
Weight	6.2 lbs (2.8kg)

*depending on load, frequency and power setting

Factory Service

The RYCOM 8872 were designed for dependable operation with recommended yearly adjustment or calibration. If, however, your 8872 Series is not working properly, first call the factory to receive an RMA number, then return it to the factory for repair. Send it prepaid to:

RYCOM Instruments, Inc.
9351 East 59th Street
Raytown, Missouri 64133 USA
816.353.2100 or 800.851.7347
Fax: 816.353.5050

We will repair and ship the instrument back within 10 working days, or advise you if the instrument is unrepairable.

Note: There is a minimum charge for repair and handling.

When shipping your 8872 for service, be sure to include:

- a) name, address, and phone number of your contact
- b) a brief description of the trouble
- c) the return shipping address and department mail address, along with any special shipping instructions
- d) or contact us for a "Return for Service Form"
- e) RMA number

Packing Instructions

Remove all batteries, and place the unit in the original shipping carton, or equivalent sturdy container. Add packing material around all sides of the unit. Seal the shipping container with strong tape. Mark the shipping container:

FRAGILE ELECTRONIC EQUIPMENT

Warranty

THIS INSTRUMENT IS UNDER WARRANTY FOR ONE YEAR FROM THE DATE OF DELIVERY AGAINST DEFECTS IN MATERIAL AND WORKMANSHIP **(EXCEPT BATTERIES)**. WE WILL REPAIR OR REPLACE PRODUCTS THAT PROVE TO BE DEFECTIVE DURING WARRANTY PERIOD.

THIS WARRANTY IS VOID IF, AFTER HAVING RECEIVED THE INSTRUMENT IN GOOD CONDITION, IT IS SUBJECTED TO ABUSE, UNAUTHORIZED ALTERATIONS OR CASUAL REPAIR.

NO OTHER WARRANTY IS EXPRESSED OR IMPLIED. THE WARRANTY DESCRIBED IN THE PARAGRAPH SHALL BE IN LIEU OF ANY OTHER WARRANTY, INCLUDING BUT NOT LIMITED TO, ANY IMPLIED WARRANTY OF MERCHANTABILITY OR FITNESS FOR A PARTICULAR PURPOSE. WE ARE NOT LIABLE FOR CONSEQUENTIAL DAMAGES.